

NEW MIGHTY MICROS

AC ELECTRIC DRIVE
DC SCISSOR LIFTS



MIGHTY MICROS MEAN BUSINESS

Our new micro scissor range represents a significant new presence in the low-level access arena. Ideal for easy accessibility into tight spaces, it has a quiet and swift electric drive.









The SJ3213 micro and SJ3219 micro combines low cost of ownership with our renowned product support.









DESIGNED FOR RENTAL

Skyjack became an industry leader by providing machine features that combine durability, quality, and serviceability, making our products world renowned for product reliability. Our team understands the importance of maximum uptime, so our equipment is designed to provide just that. All major service points are easily accessible, enabling straightforward troubleshooting and repairs.



Rental companies and major contractors face increasing demands for sustainability information. Skyjack has introduced its ECO mark to support our customers by providing products that deliver benefits in environmental performance and long-term sustainability. Skyjack's E-Drive scissors' ECO benefits include:

-  12% overall carbon saving compared to traditional 19ft DC scissor
-  ZERO emissions
-  <70 dB inherently quiet machine operation (excl. alarms)
-  White noise/broadband alarms - *optional*
-  90% recyclable (by weight)
-  ECOTRAY leak containment - *optional*
-  Bio-degradeable hydraulic oil - *approved*
-  Telematics – remote diagnostics reduces site visits (operational carbon foot print)

			
SJ3213 micro	19' (5.8 m)	13' (3.96 m)	20" (0.5 m)
SJ3219 micro	24' 1" (7.3 m)	18' 1" (5.5 m)	20" (0.5 m)
			
SJ3213 micro	32" (0.81 m)	60" (1.5 m)	2.1 mph (3.4 km/h)
SJ3219 micro	32" (0.81 m)	60" (1.5 m)	2.1 mph (3.4 km/h)
			
SJ3213 micro	1,897 lbs (861 kg)	25%	500 lbs (227 kg)
SJ3219 micro	2,675 lbs (1,214 kg)	25%	500 lbs (227 kg)

† Capacities, and machine weights may differ when options are added. Preliminary specifications at time of printing. Consult your local area sales representative for details. All Skyjack warranties are subject to express limited warranty and all of other related terms, policies and procedures, as amended from time to time. Please refer to www.skyjack.com/warranty-service

ELECTRIC DRIVE: MORE PRODUCTIVITY, PERFORMANCE AND MANEUVERABILITY

Variable speed brushless AC electric front wheel drive provides exceptional duty cycles. Fully proportional drive and lift controls offer, superior drive – more efficiency, controllability, and improved torque.

E-Drive improves controllability and provides consistent power, torque, and traction. With over 25% gradeability climbing loading ramps is easy and excellent all-round job site performance and maneuverability is achieved.

Skyjack's focus on improving productivity and reducing lifetime maintenance expenditure improves your cost of ownership.

- More return on investment with maintenance free brushless AC Electric Drive motors
- More runtime per charge with less power consumption and lower battery maintenance
- More sustainability with zero leakage drive motors, for clean operation
- More flexibility and utilization with low GVW and wide non-marking tires providing low ground pressures and help protect finished flooring
- More control with spring applied, electrically released brake
- Drivable at full height
- 25% gradeability and consistent torque
- Tight steering angle provides excellent job site maneuverability
- Fully proportional drive and lift controls
- Minimal maintenance on wheel motors

COMPACT AND LIGHTWEIGHT

Designed to fit most elevators and to work in environments where space is at a premium while at the same time providing a substantial work area.

- 2-Person platform capacity
- Passes through a standard door rails up
- Up-and over capability
- Single point emergency lowering
- Low floor loading
- Lifting lugs and tie downs located on all 4 corners
- Forklift pockets



WIND RATED DESIGN

Designed with both indoor and outdoor use in mind, the micro range has an optional wind rating at 12.5m/s for one person on the SJ3213 micro up to 12' (3.65 m) and the SJ3219 micro up to 16' (4.87 m). This increases the application possibilities and increases rate of return.



SKYCODED™

Skyjack's standard color-coded and numbered wiring now combines with an externally visible onboard diagnostic system. This provides real-time data, easy to understand machine faults, written in plain and simple language, without the need to open service trays. No plug-in calibration is necessary for day-to-day troubleshooting, including load sensing information. The New CAN-bus based control system provides increased data points for telematics integration.



LARGER WORK AREA

Sturdy all steel design with checker plate deck incorporates roll out extension deck increases work area and provides up-and-over capability:

- Large platform deck with 500 lbs capacity
- 20" extension deck (220 lbs capacity)
- Permanent anti-slip checker plate floors
- Full height solid rails
- Standard self-closing full height gate provides easy platform entry
- Multiple lanyard attachment points



EASE OF MAINTENANCE

Swing out trays provides access to service components in one location:

- Two x 12 V Batteries
- 650W Charger

SIMPLE ROBUST CONTROLS

Removable, high strength and impact resistant composite upper control box with integrated shroud.

- Fully protected proportional CAN joystick with a safety enable trigger, thumb steer, selector switches, low battery light indication, horn and emergency stop
- 6 ft (1.2 m) control cable for ease of walking through entrances or doorways
- Common control box is interchangeable with E-Drive series machines
- Lift/drive switch timed-out delay to prevent inadvertent operation
- Lockable battery disconnect switch, located at the base controls, prevents unauthorized operation



ELEVATE LIVE

On each Skyjack machine a QR code provides operators access to critical machine information, including the machine's current state of health, pre-use inspection guides, and familiarization materials.

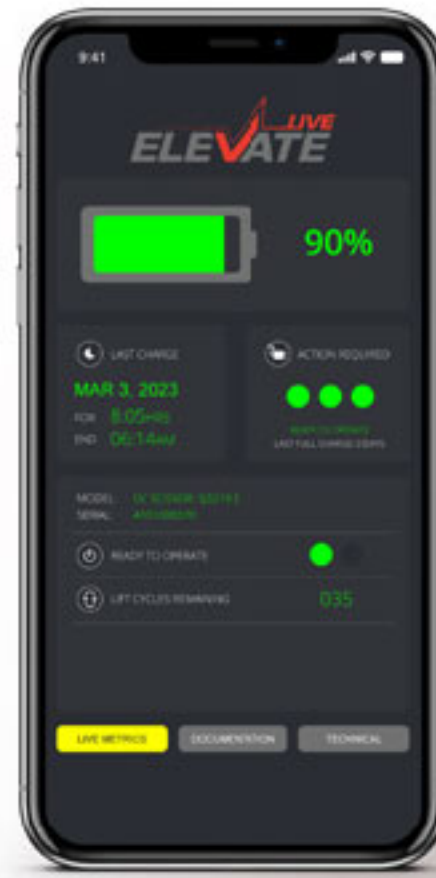

OPTIONAL FEATURES

ELEVATE

MORE THAN TELEMATICS

ELEVATE provides the actionable insights to make your business more efficient. Information specific to Skyjack machines communicated through ELEVATE include:

- Ready to operate
- Overload detection and reporting
- True machine utilization (time loaded at height)
- CAN data and alerts
- Full data access

ECOTRAY

ECOTRAY has been designed with essential machine functionality in mind. It prevents potential leaks from hydraulic systems dripping onto floors and other internal components.*

- Protects against entire hydraulic system and steering cylinders
- Capable of containing ALL machine oil by volume
- Avoids cumbersome diaper attachment
- Prioritizes machine functionality
- Factory fit or field install option
- Installed in less than 10 minutes, absorbent pads changed in seconds

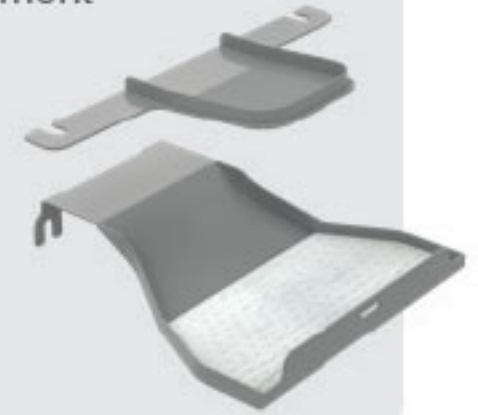

ACCESSORYZERS™

Skyjack's approved accessories are designed to add functionality to your machine and convenience for the operator.



*DC electric scissor ECOTRAY configurations vary by model

SJ3213/19 micro

ELECTRIC SCISSORS



STANDARD FEATURES

- Drivable at full height
- Variable speed, dual front wheel electric drive
- Motor guards
- Dual holding brakes
- SKYCODED™ Color coded and numbered wiring system
- On-board visual interface with diagnostic capabilities
- Shroud style, impact resistant composite control box with extended cable
- Low battery indicator light on control box
- Proportional controls for drive & lift functions
- 20" (0.5 m) Roll out extension deck
- 24V DC Power source
- 2 x 12V Batteries
- Low voltage battery protection
- 25% Gradeability
- Solid rubber, non-marking tires
- Fixed pothole protection system
- Tilt alarm with drive & lift cut-out (3° x 1.5°)
- All motion audible alarm
- Lanyard attachment points
- Operator horn
- Forklift pockets and tie down / lift lugs
- Overload sensing system
- Solid rails
- Full height spring hinged entry gate
- Telematics ready
- 2-Year Gold Leaf Warranty (5-year structural warranty)



- 12% overall carbon saving compared to traditional 19ft DC scissor



- ZERO emissions



- <70 dB inherently quiet machine operation (excl. alarms)
- White noise/broadband alarms - *optional*



- 90% recyclable (by weight)



- ECOTRAY leak containment - *optional*
- Bio-degradeable hydraulic oil - *approved*



- Telematics – remote diagnostics reduces site visits (operational carbon footprint)*



* Only available with ELEVATE telematics

NA/ENG/01/2024



SJ3213/19 micro ELECTRIC SCISSORS

Dimensions	SJ3213 micro	SJ3219 micro
A Work Height	19' (5.8 m)	24' 1" (7.3 m)
B Raised Platform Height (Indoor)	13' (3.96 m)	18' 1" (5.5 m)
C Raised Platform Height (Outdoor Optional)	12' (3.65 m)	16' (4.87 m)
D Lowered Platform Height	32" (0.81 m)	36" (0.91 m)
E Overall Width	32" (0.81 m)	32" (0.81 m)
F Overall Length	60" (1.5 m)	60" (1.5 m)
G Stowed Height (Rails Up)	75.8" (1.9 m)	79.5" (2.0 m)
H Platform Width (Outside Dimension)	27.5" (0.7 m)	27.5" (0.7 m)
I Platform Length (Outside Dimension)	60" (1.5 m)	60" (1.5 m)

Specifications	SJ3213 micro	SJ3219 micro
Extension Deck (Roll Out)	20" (0.5 m)	
Ground Clearance (Lowest Point)	1" (2.5 cm)	
Ground Clearance (Highest Point)	3.25" (8 cm)	
Wheelbase	49.5" (1.26 m)	
Weight	1,897 lbs (861 kg)	2,675 lbs (1,214 kg)
Gradeability	25%	
Turning Radius (Inside)	2.5" (6.4 cm)	
Turning Radius (Outside)	64.7" (1.64 m)	
Lift Time (With Rated Load)	25 sec	25 sec
Lower time (With Rated Load)	18 sec	26 sec
Drive Speed (Stowed)	2.1 mph (3.4 km/h)	
Drive Speed (Raised)	0.4 mph (0.6 km/h)	
Maximum Drive Height (Indoor)	Full Height	
Maximum Drive Height (Outdoor)	12' (3.65 m) (OPT)	16' (4.87 m) (OPT)
Capacity (Overall)	500 lbs (227 kg)	
Distributed Capacity (Extension Deck)	220 lbs (99.5 kg)	
Local Floor Load (With Rated Load)	152 psi (1,047 kPa)	175 psi (1,207 kPa)
Overall Floor Load (With Rated Load)	178 psf (8.5 kPa)	235 psf (11.3 kPa)
Maximum # of persons at 0 mph (0 m/s) wind rating	2	
Maximum # of persons up to 28 mph (12.5 m/s) wind rating	Optional 1	
Tire Type	Solid, N/M	
Tire Size	10 x 4	

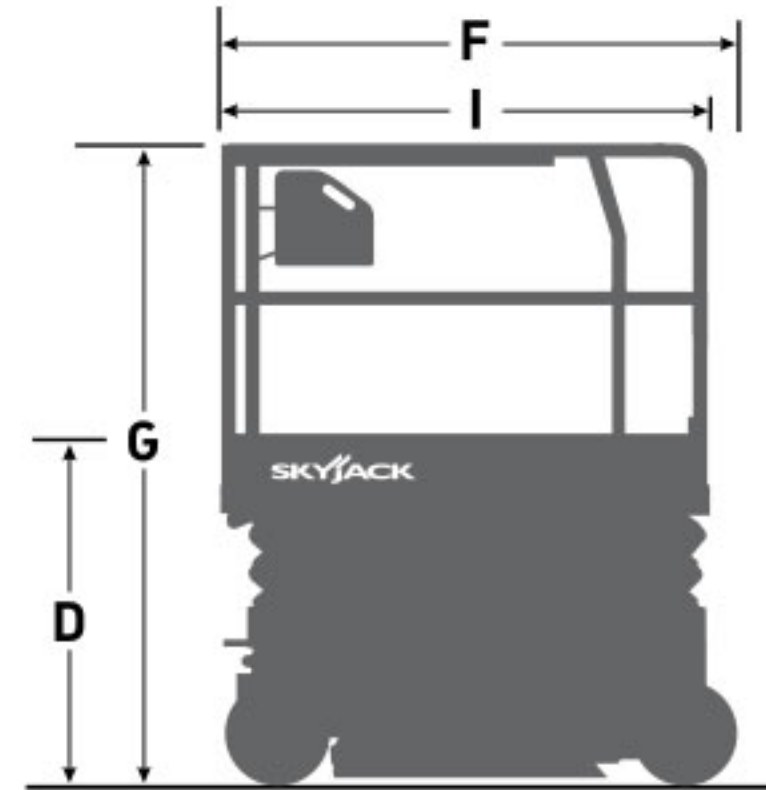
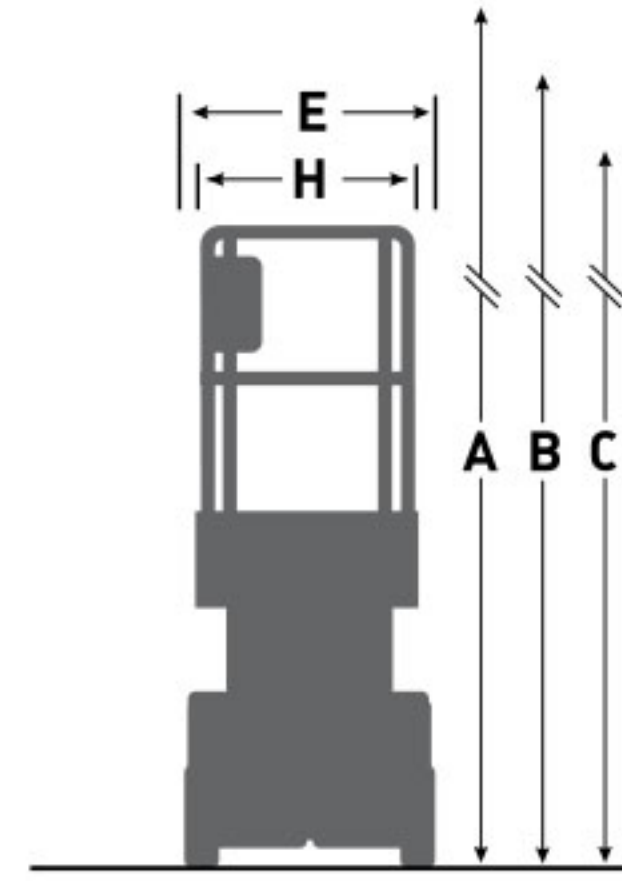

ACCESSORYZERS ‡

- ECOTRAY leak containment system
- Secondary Guarding Lift Enable (SGLE)
- Perimeter lights

OPTIONS †

- Dual flashing lights
- AGM Battery option
- 28 mph (12.5 m/s) Wind rating
Up to 12' (3.65 m) for SJ3213 micro and 16' (4.87 m) for SJ3219 micro
- White noise alarm
- 110V AC Outlet on platform with GFI
- AGM Batteries
- Lockable swingout trays
- Non-destructive testing
- ELEVATE telematics (1-year, 3-year or 5-year plans available)
- Extended warranty (3-year or 5-year plans available)

(844) 432-4724
fairchildequipment.com

www.skyjack.com

† Standard lead times may be increased when optional equipment is added, consult factory.
 ‡ Capacities and machine weights may differ when accessories and options are added.





Skyjack Head Office
55 Campbell Rd.
Guelph, ON Canada N1H 1B9

Sales Inquiries: 1-877-755-4387 (1-877-SJLIFTS)
Main Switchboard: 1-800-265-2738
Tel: 519-837-0888
Fax: 519-837-8104
Email: skyjack@skyjack.com

www.skyjack.com



(844) 432-4724
fairchildequipment.com