



RICO Model # HPWH-EX-80

EX-80

APPROVED FOR OPERATION IN:

- Class 1, Division 1 & 2, Group D
- Class 2, Division 1 & 2, Group G
- Hazardous Environment

Pallet Walkie Handler



For more information, or to find
your nearest Hyster® dealer, go to:

www.Hyster.com

RICO

Since 1984 RICO Manufacturing has been designing and manufacturing specialized lift trucks for the most rigorous and demanding industries around the globe.

RICO's hazardous products division continues to be the leading manufacturer of Explosion Proof equipment and forklifts in the United States.

RICO's standard for excellence in design, manufacturing and installation results in the best EX-rated lift trucks on the market today. All of our explosion-proof lift trucks are designed around operator visibility, friendly maintenance and outstanding parts/service support.



98%
WORK PERFORMED
IN-HOUSE



FINANCIALLY
INDEPENDENT

SAFETY FEATURES

Safety is a critical focus for every successful organization – forklift safety starts with RICO.



RIGOROUS TESTING

Built to UL583 specifications, and approved by FM Global, a Nationally Recognized Testing Laboratory.



PROTECTED SURFACES

Exposed components on the perimeter of the truck, including forks, are protected with brass and aluminum alloys eliminating the possibility of mechanical sparking.



STATIC CONDUCTIVE WHEELS

Prevent sparks, helping to provide a working environment with reduced peril and hazardous conditions.



EXCEPTIONAL MANEUVERABILITY

Compact design increases ability to operate in narrow aisles or small spaces.



Choose RICO for exceptional performance and explosion proof features.

FEATURES & BENEFITS

EX-80

RICO Model # HPWH-EX-80

DRIVE, PUMP AND ELECTRICAL ENCLOSURES

house only electrical components and are approved to be included on EX-rated lift trucks. All RICO enclosures have been tested for approval in an EX-rated environment by FM Global.



FLEXIBLE CONDUIT (FC) CABLES house regular cabling, which is sealed to ensure safe use in an EX-rated environment. The FC Cable provides flexibility and space saving.



EASE OF MAINTENANCE

Easy access to serviceable components.



REDUCED COSTS

Battery box eliminates the need for an EX battery.



INVENTORY CONTROL

Industry standard components for local servicing and dealer sourcing.



OPERATOR EFFICIENCY

Heads up BDI display enables clear view of battery status in normal operating position.



APPROVED FOR OPERATION IN:

- Class 1, Division 1 & 2, Group D
- Class 2, Division 1 & 2, Group G
- Hazardous Environment

SPECIFICATIONS

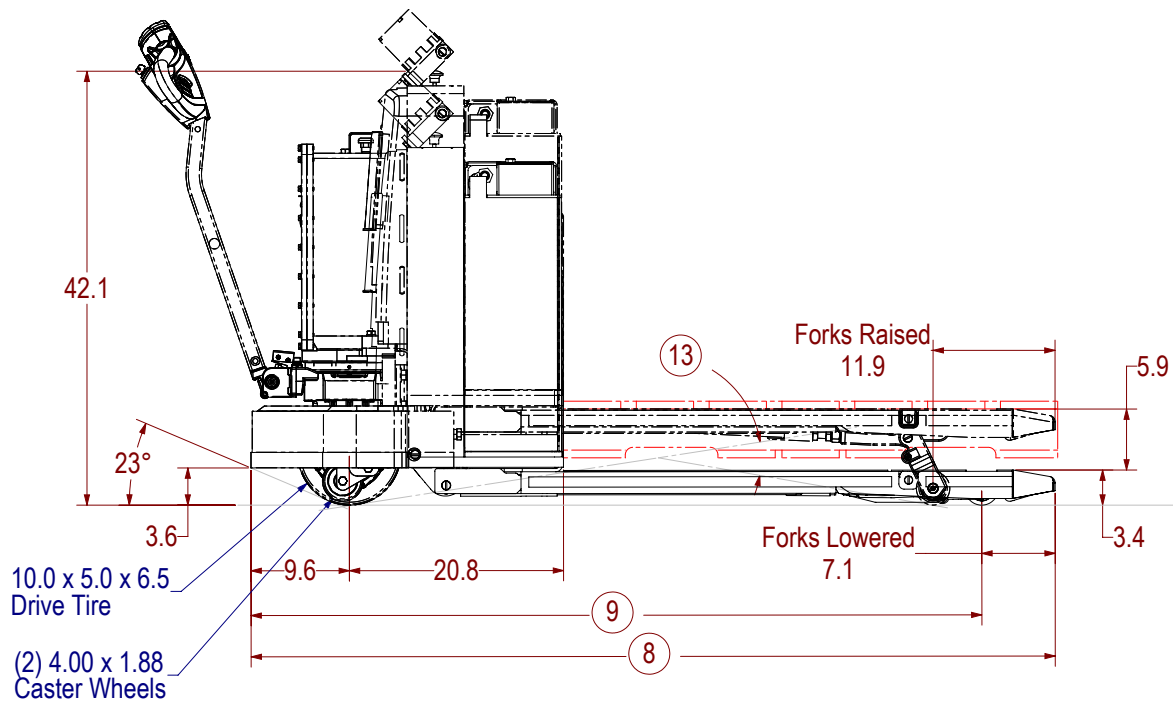
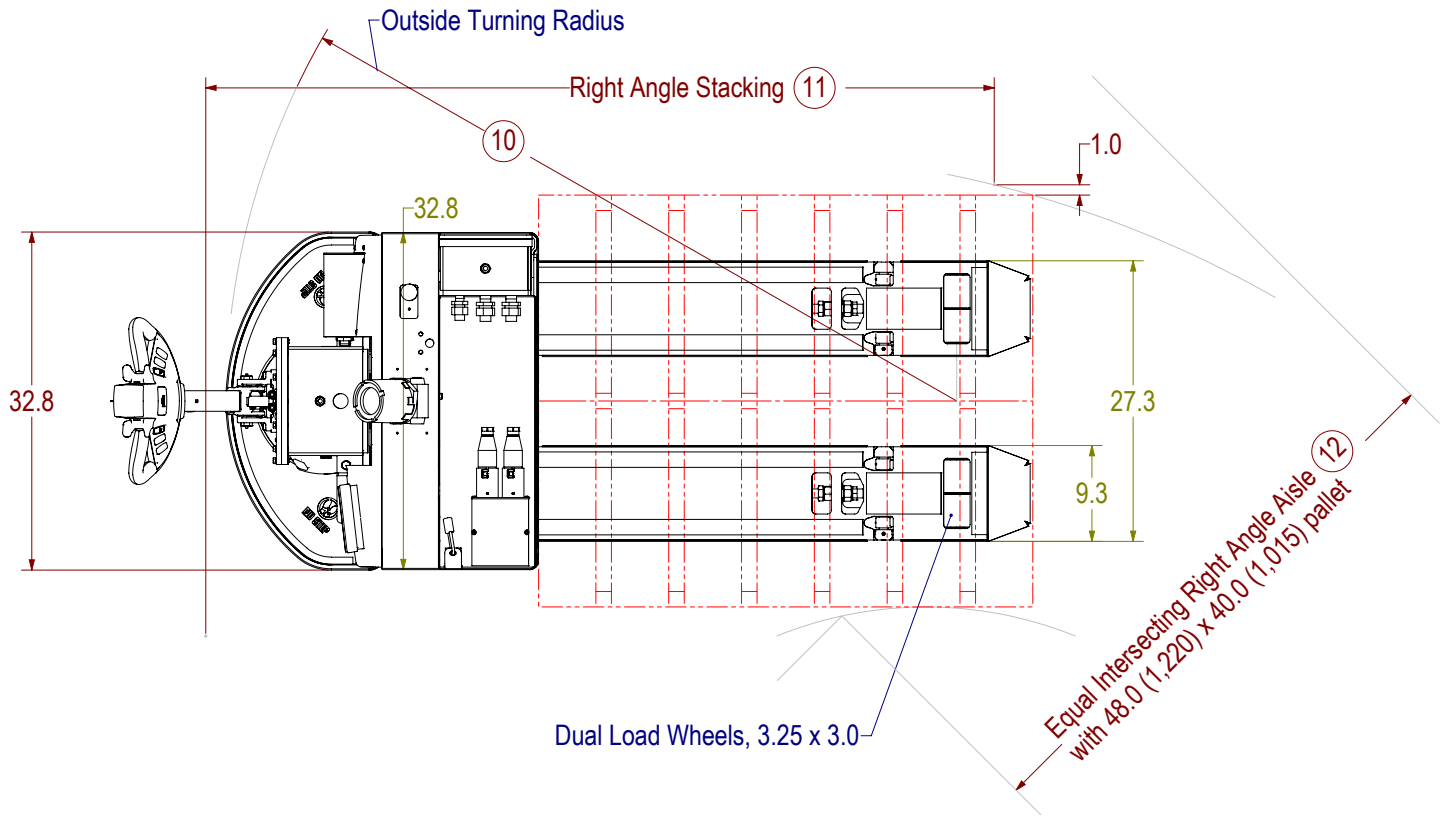



GENERAL

1	Manufacturer			RICO
2	Model			HPWH-EX-80
3	Capacity, rated	lb (kg)		8,000 (3,628)
4	Voltage			24

DIMENSIONS

5	Nominal fork length	in (mm)	36.0 (915)	42.0 (1,067)	48.0 (1,219)
6	Width across forks	in (mm)		27.25 (692)	
7	Chassis length	in (mm)		20.8 (527)	
8	Overall length	in (mm)	66.12 (1,679)	72.12 (1,831)	78.12 (1,984)
9	Wheelbase	in (mm)	49.4 (1,254)	55.4 (1,407)	61.4 (1,560)
	Wheelbase, raised	in (mm)	44.7 (1,135)	50.7 (1,287)	56.7 (1,440)
10	Turning radius, lowered	in (mm)	59.0 (1,498)	65.0 (1,651)	71.0 (1,803)
	Turning radius, raised	in (mm)	54.5 (1,384)	60.5 (1,536)	66.5 (1,689)
11	Right angle aisle stack w/ 40" x 48" pallet	in (mm)	86.9 (2,207)	89.1 (2,263)	92.3 (2,344)
12	Equal intersecting aisle w/ 40.0" wide pallet	in (mm)	57.4 (1,457)	60.1 (1,526)	62.9 (1,596)
13	Grade clearance, center wheelbase, raised with pallet	%	39	34	31
	Grade clearance, forks first, raised with pallet	%		39	
	Grade clearance, chassis first, raised with pallet	%		42	
14	Overall lift height (TOF)	in (mm)		9.4 (238)	
15	Overall fork lifting height	in (mm)		6.0 (154)	

BATTERY

16	Battery compartment size, (L x W x H)*	in		26.0 x 9.25 x 24.4
	Battery compartment size, (L x W x H)*	(mm)		(660 x 235 x 619)
18	Battery weight - minimum	lb (kg)		525 (238)
	Battery weight - maximum	lb (kg)		575 (260)

PERFORMANCE

19	Travel speed, NL / RL mph	mph (km/h)		3.0 (4.8) / 3.0 (4.8)
20	Lift / lower speed, 24-Volt NL	seconds		4.2 / 5.3
	Lift / lower speed, 24-Volt RL	seconds		6 / 3.4

WHEEL

21	Drive tire size (Polyurethane)	in		10.0 x 5.0 x 6.5
22	Dual Load wheel size (Polyurethane)	in		3.25 x 3.0
	(Polyurethane)	in		4.0 x 1.88
23	Weight, total approx. w/o battery	lb (kg)	1,480 (671)	1,500 (680) / 1,525 (692)

BATTERY SIZE DIMENSIONS

NUMBER OF CELLS	CELL SIZE	PLATES PER CELL	CAPACITY Ah (Kwh)	LENGTH in (mm)	WIDTH in (mm)	HEIGHT in (mm)	WEIGHT lbs (kg)
12	90	7	270 (6.2)	25.3 (644)	8.6 (218)	23.1 (586)	552 (250)



Note: Specifications included in the tables above are subject to change.

SERVICES & SUPPORT

At RICO, we know that once a lift truck ships, the real work is just beginning.



RICO products are fully supported throughout their service life by a team of dedicated experts who are true business partners.



RICO offers EX compliance evaluations and services on all RICO manufactured trucks.

On-site evaluations can be performed by RICO or one of our factory-trained authorized servicing dealers.



RICO provides our customers with the education and tools to evaluate and assess EX trucks in the field to determine whether they are still within compliance.

ROI

Extend the return on investment of your vehicle and help increase the safety of your team and your facility — schedule an EX compliance evaluation or EX training today.



Join the Conversation



RICO is American Owned & Operated

RICO Manufacturing, Inc.
691 West Liberty Street
Medina, OH 44256
330.723.4050
www.RICOequipment.com

For more information, or to find your nearest Hyster® dealer, go to:

www.Hyster.com



(844) 432-4724
fairchildequipment.com

